

FRONTE - 1:10

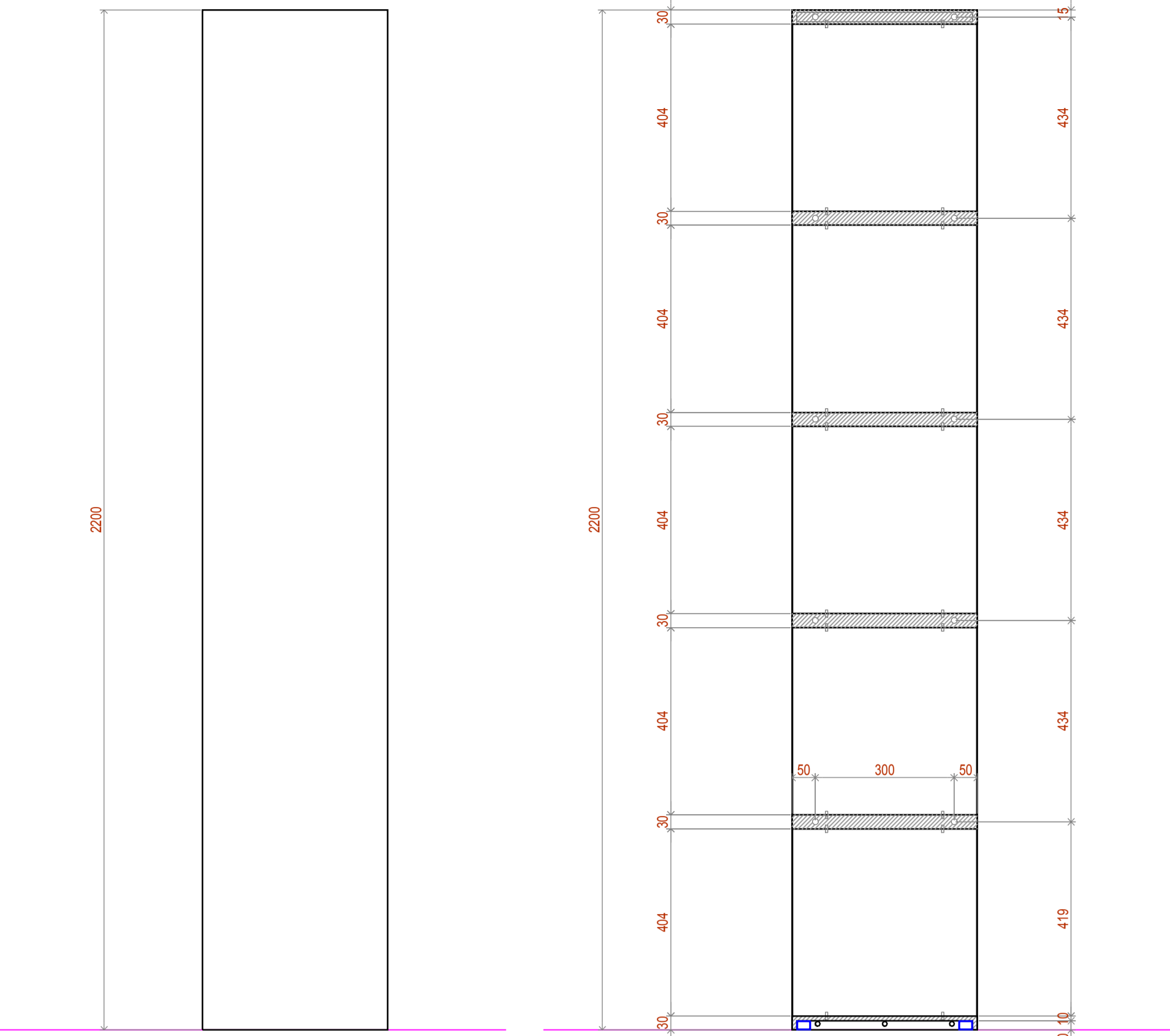

FIANCO - 1:10

SEZIONE - 1:10

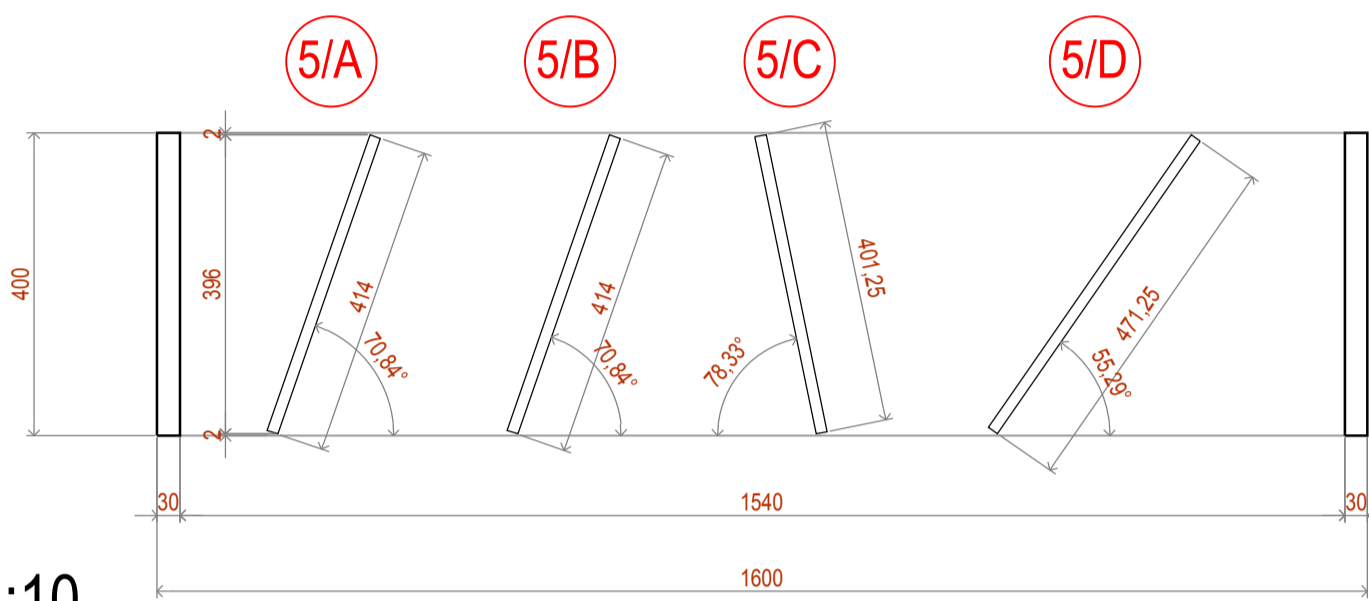

PIANTA "A" - 1:10

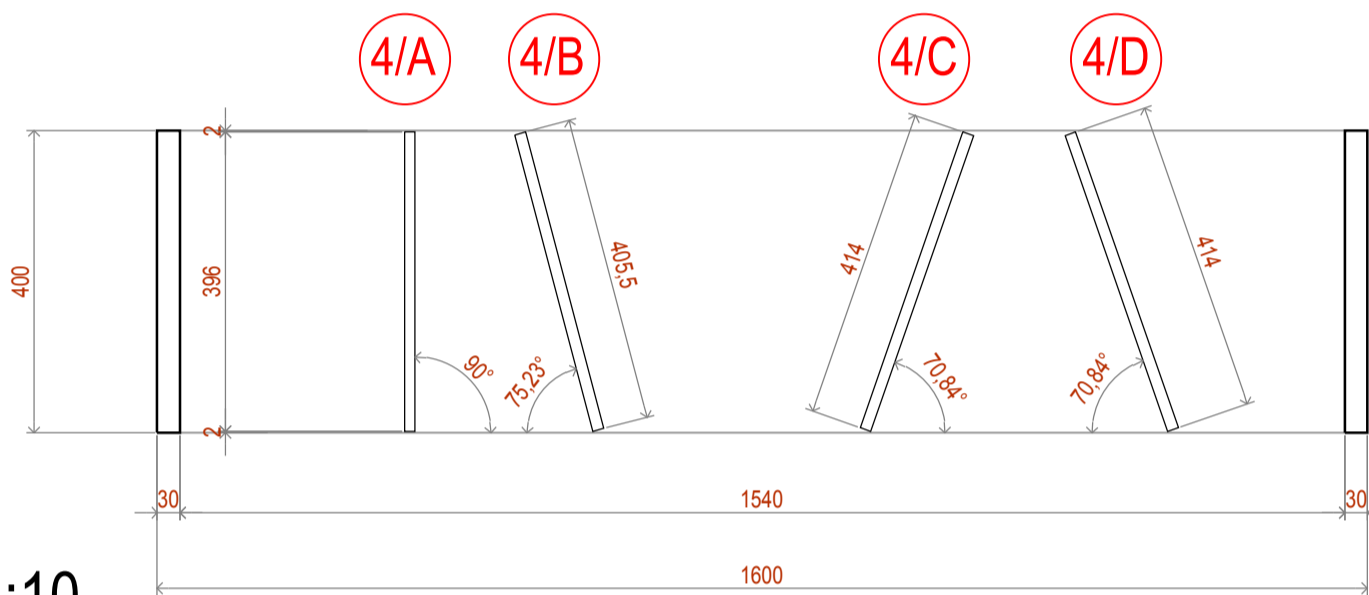
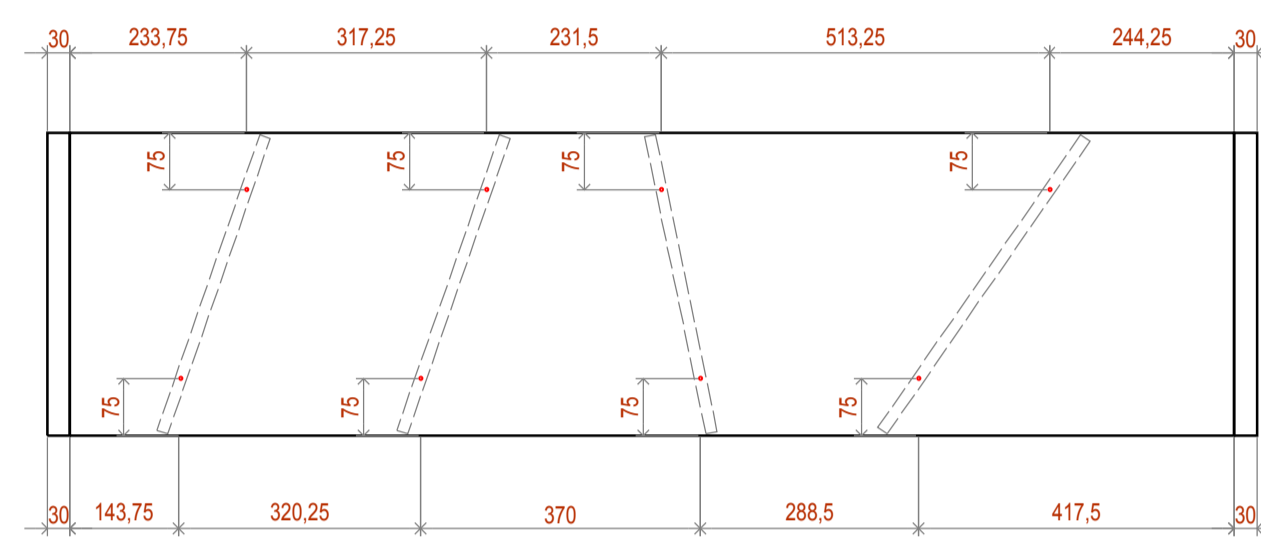

PIANTA "B" - 1:10

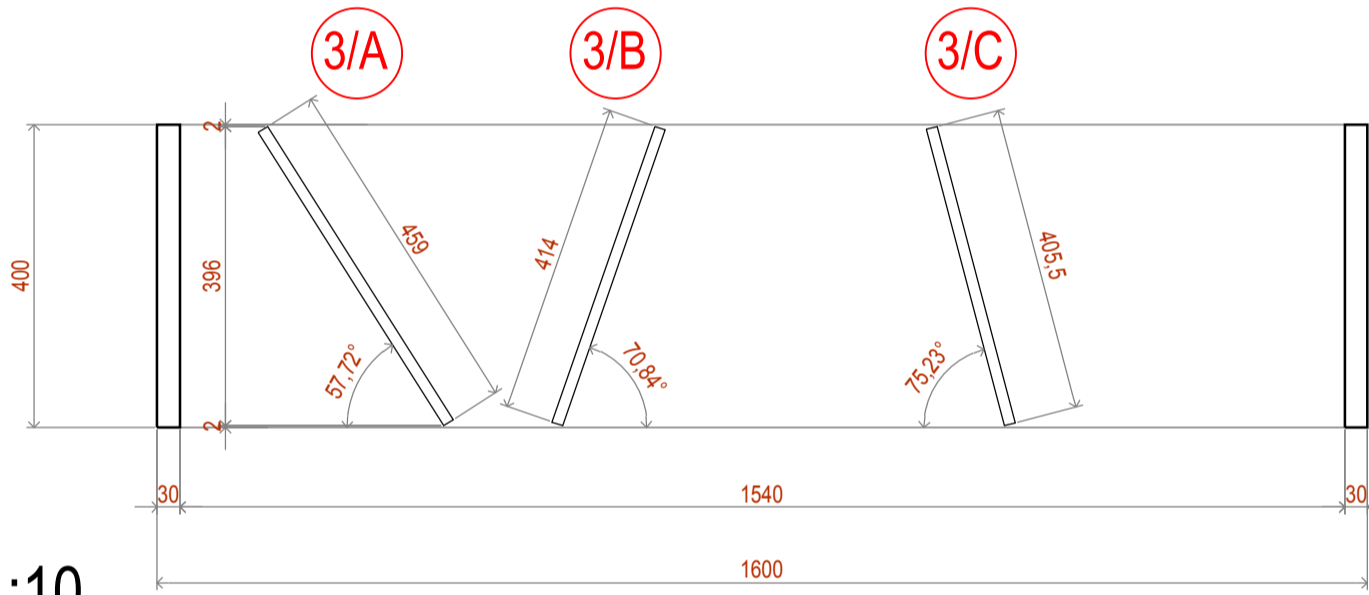
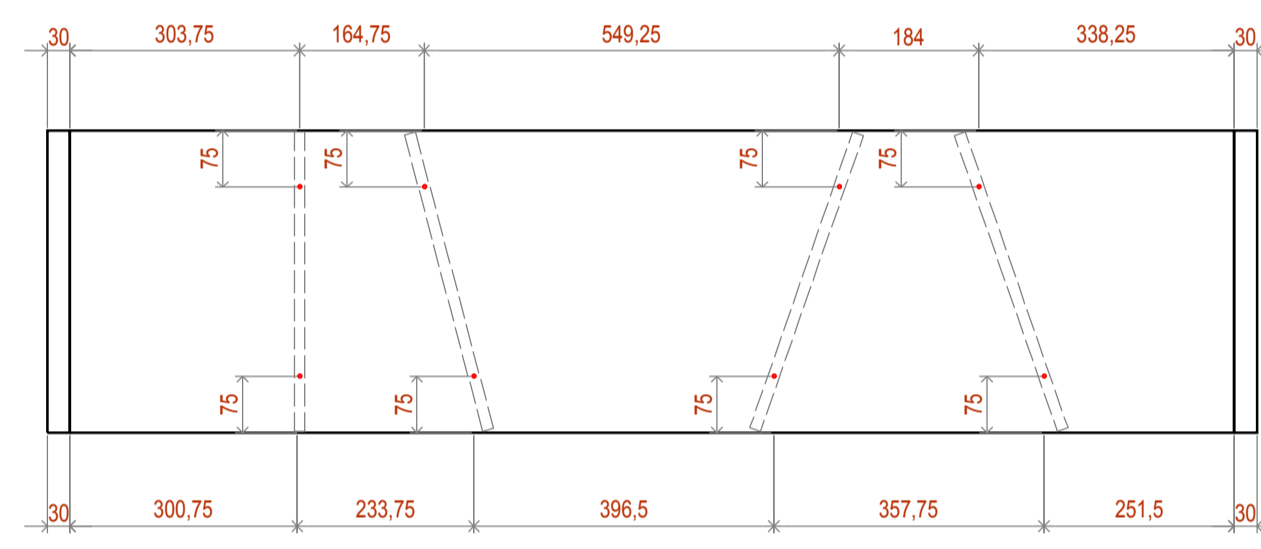

PIANTA "C" - 1:10

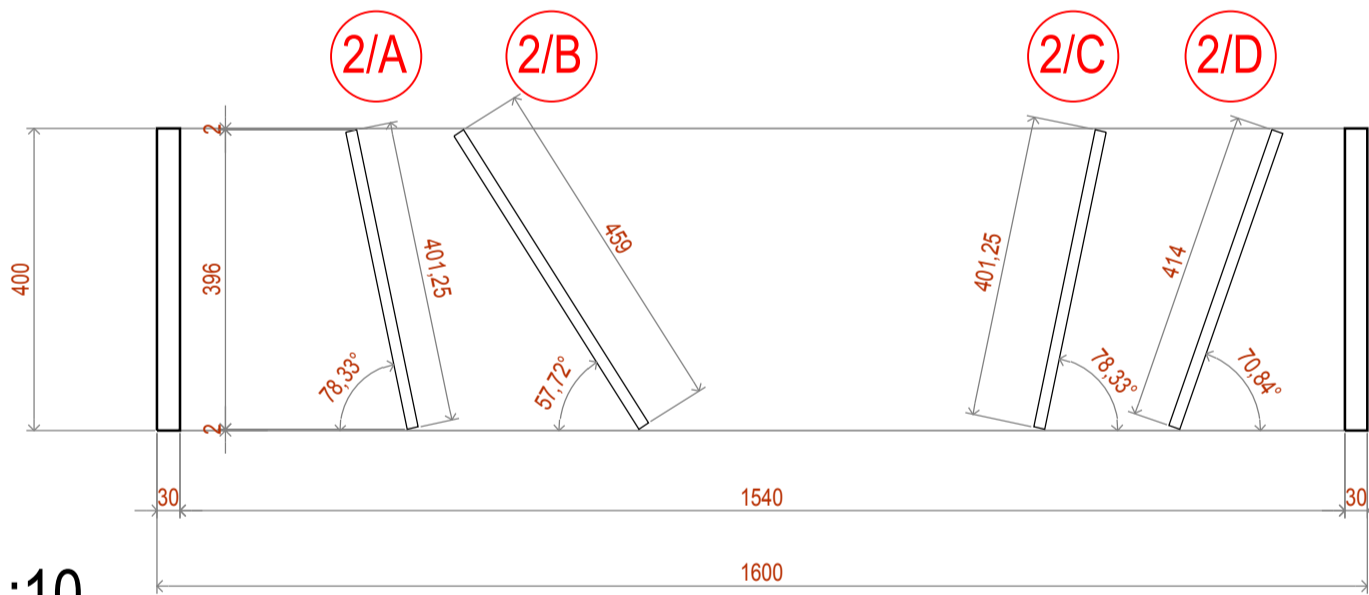
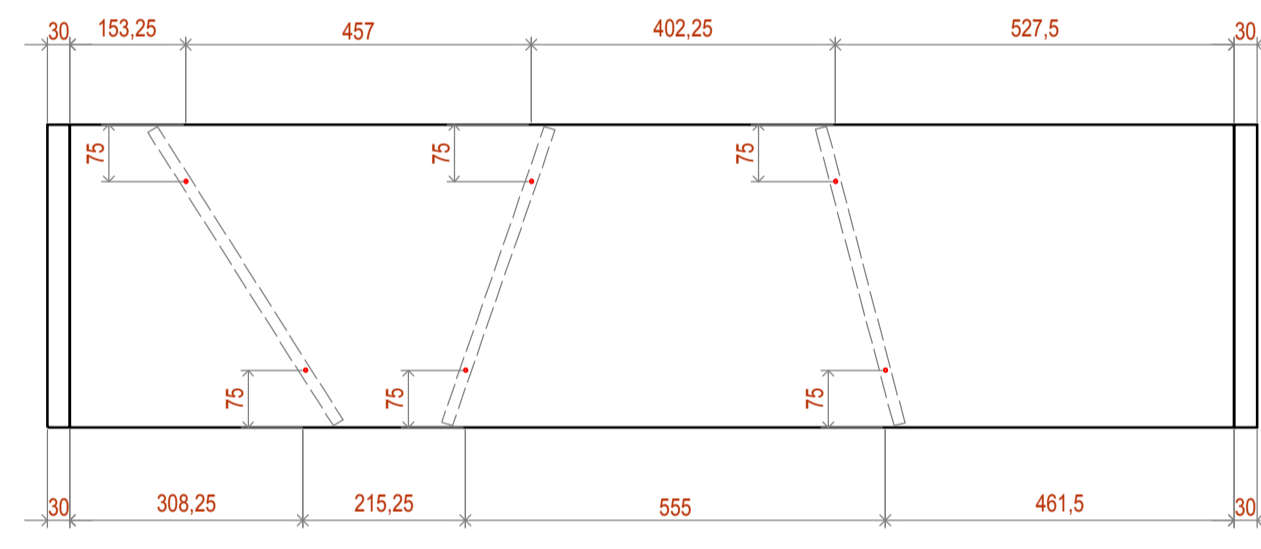

PIANTA "D" - 1:10

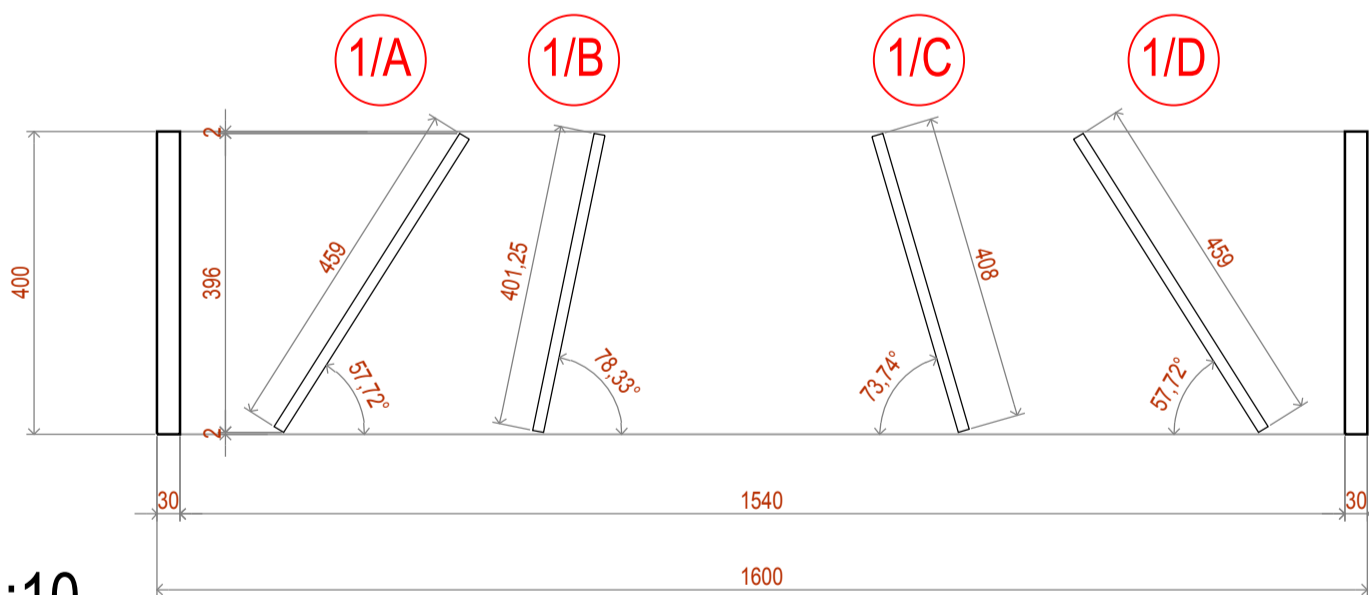
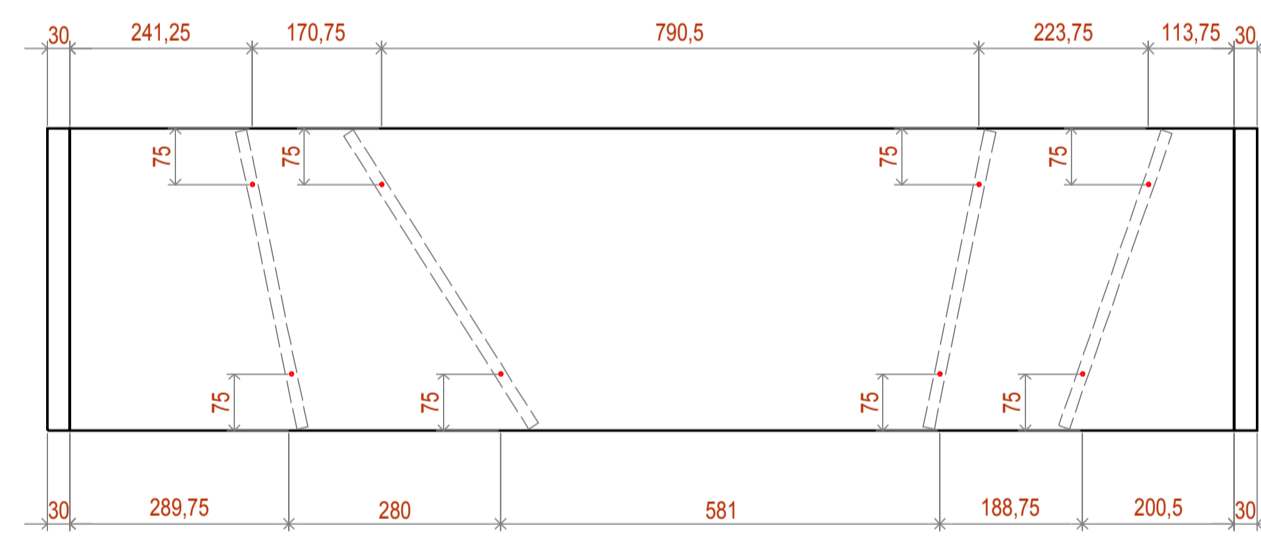

PIANTA "E" - 1:10

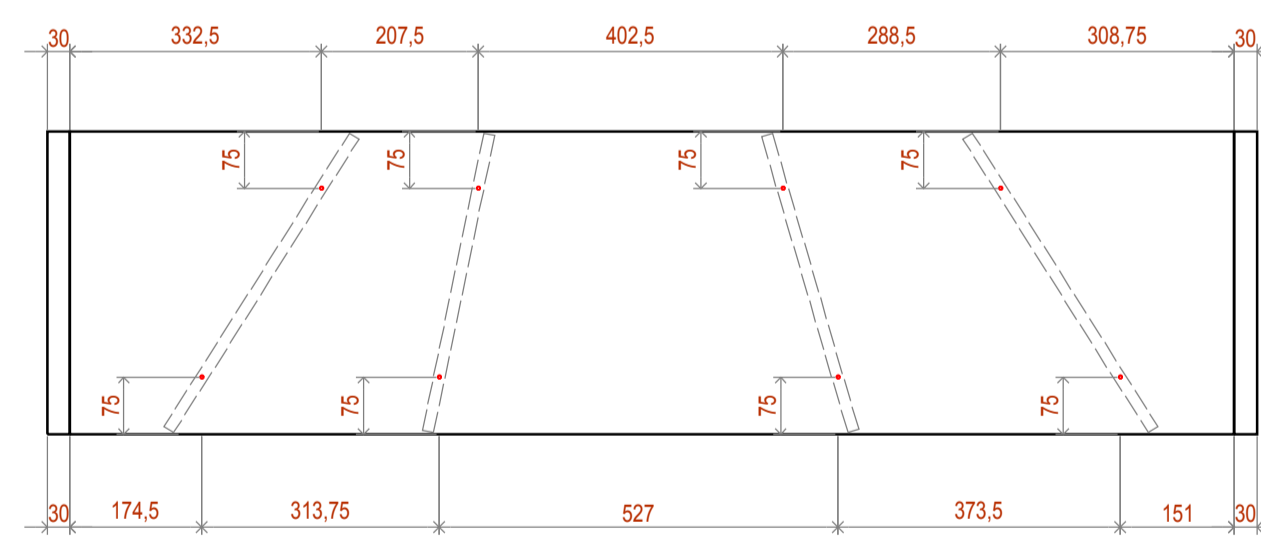

SCHEMA FORATURE SPINE NYLON PER DIVISORI IN MARMO - 1:10

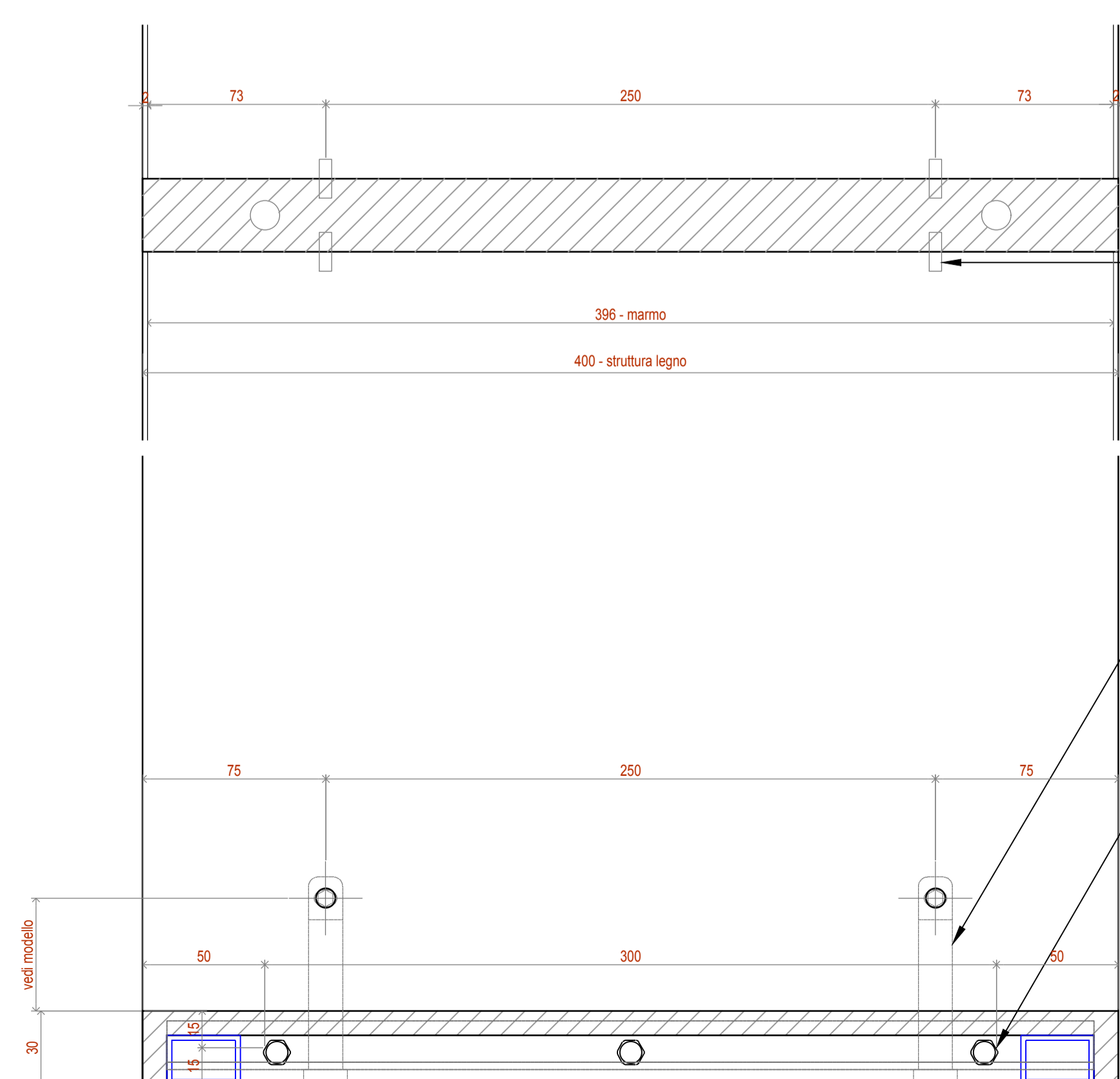

DETTAGLIO FORATURE - 1:2

spine in Nylon o legno per divisori marmo - Ø5x16mm

espansori a scomparsa "CAMAR" da inserire nelle spalle

giunti invisibili LAMELLO - Mx2

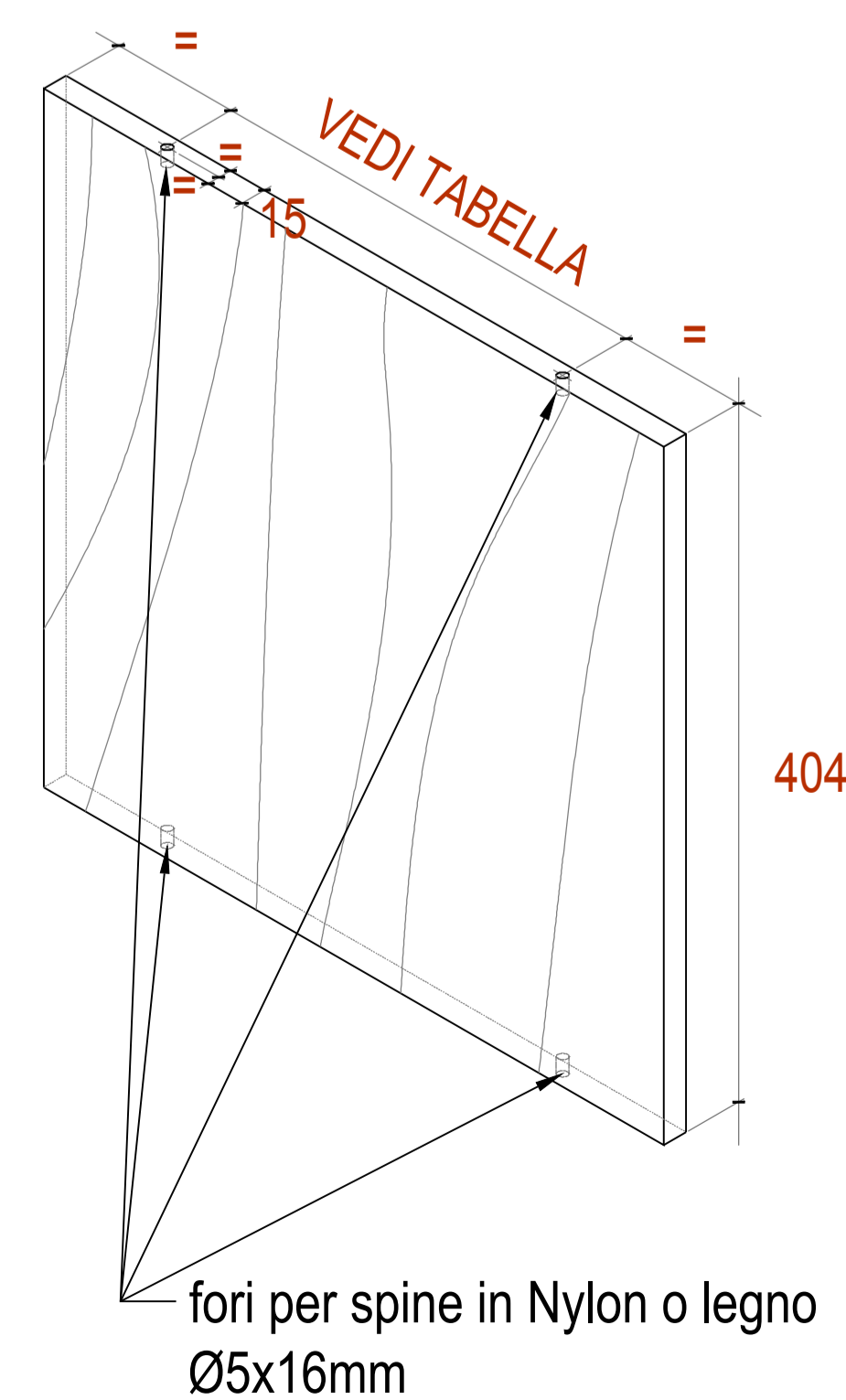

SETTI IN MARMO - 1:4

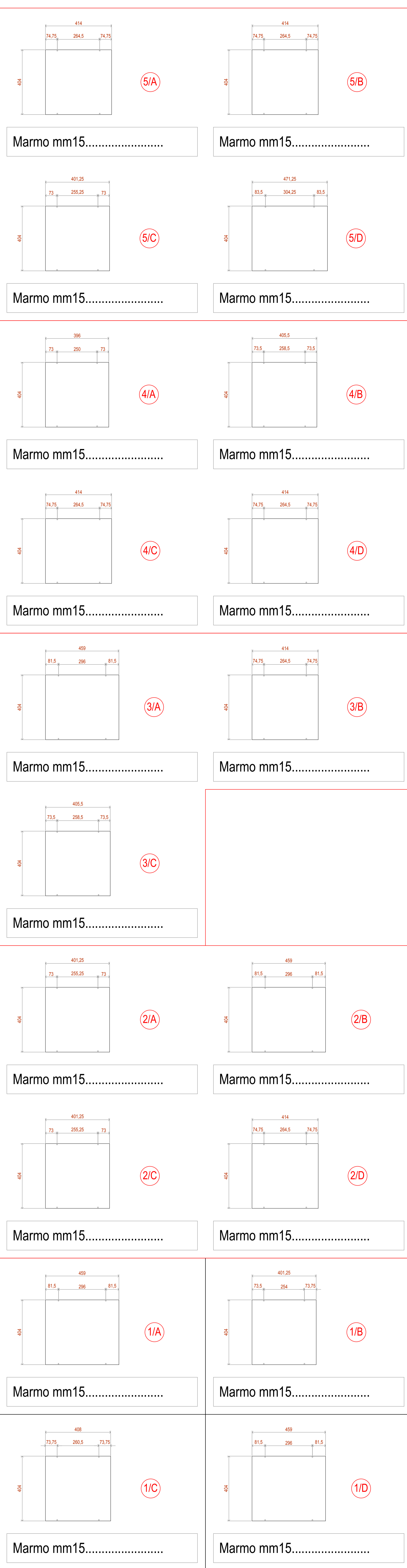

STRUTTURA	SETTI VERTICALI
Noce satinato mm30	Marmo 15mm Calacatta
Frassino nero mm30 satinato	Marmo 15mm Grigio Carnico venato satinato
Frassino nero mm30 satinato	Marmo 15mm Verde Alpi venato satinato
Frassino nero mm30 satinato	Marmo 15mm Nero Marquina venato satinato